

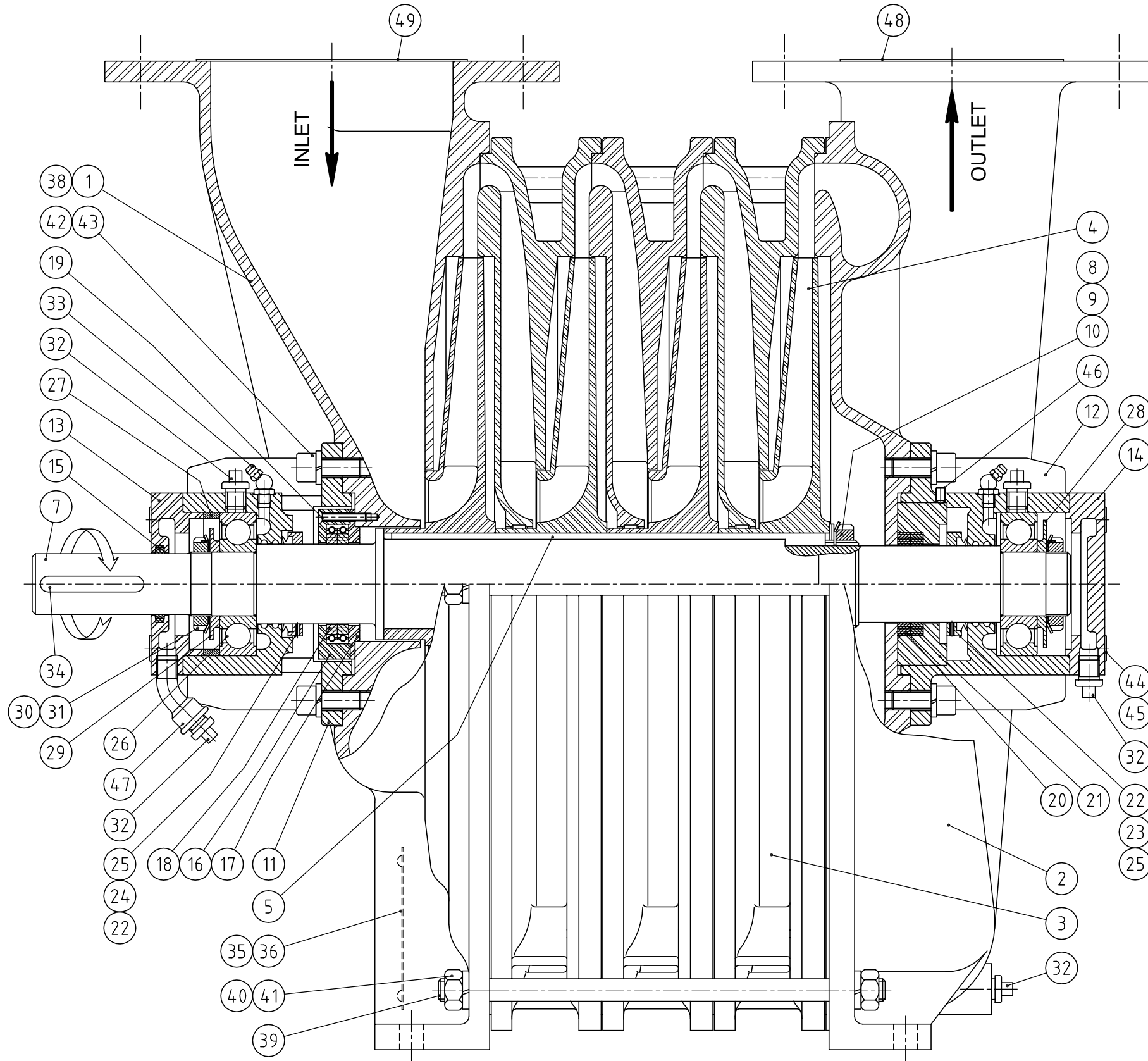

Drawing for information.  
See detail on DWG N° 20-AB2A



49	1	S.0624	COVER, PORT / DN150			
48	1	S.0417	COVER, PORT / DN125			
47	1	S.3004	ELBOW 45° 1/4" GAS M-F			
46	1	AHc M06-010i	SCREW, AHc M6-10		S.STEEL	
45	8	W10	WASHER LOCK, W10			
44	8	CHc M10-025	SCREW, CHc M10-25			
43	8	W12	WASHER LOCK, W12			
42	8	CHc M12-030	SCREW, CHc M12-30			
41	Variable	H M14	NUT, H14			
40	11	W14	WASHER LOCK, W14			
39	6	See chart I	TIE ROD	010	C.STEEL	
38	1	S.1802	VALVE WARNING PLATE	008		
37	1	S.1801	SURGE WARNING PLATE ( NOT SHOWN )	092	ALUMINIUM	
36	8	CT02.89-008	RIVET, Ø2,89-8			
35	1	S.1808	NAME PLATE	596	ALUMINIUM	
34	1	S.0408	KEY, COUPLING	003	C.STEEL	
33	2	S.0218	CRANKED LUBRICATOR			
32	5	S.0200	PLUG, PIPE 1/4 GAS			
31	2	S.0413	NUT, KM8			
30	2	S.0412	WASHER, MB8			
29	1	S.0463	GREASE, SLINGER Ø70 INLET SIDE	10-11	C.STEEL	
28	1	S.0407	GREASE, SLINGER Ø80 OUTLET SIDE	10-11	C.STEEL	
27	1	S.0460	SPACER, BEARING	10-40	C.STEEL	
26	2	S.0409	BEARING, BALL 6308 C3			0,63
25	6	AHC M03-006,PL	SCREW, AHC M3-6,PL			
24	1	S.4348	SET COLLAR V-RING, INLET SIDE	20-49	C.STEEL	
23	1	S.4347	SET COLLAR V-RING, OUTLET SIDE	20-49	C.STEEL	
22	2	S.4349	V-RING			
21	2	S.0454	GRAPHIT RING			
20	1	S.4414	RETAINER, GRAPHIT RING	20-126	ALUMINIUM	
19	3	FHC M05-030	SCREW, FHC M5-30			
18	2	S.0531	CARBON RING		CARBON	
17	1	S.0546	ADAPTER, CARBON RING	10-63	ALUMINIUM	
16	1	S.0545	RETAINER, CARBON RING	10-63	ALUMINIUM	
15	1	S.0414	FELT JOINT 38x48x4	005		
14	1	S.0457	CAP, BEARING -OUTLET END	10-25	CAST IRON	1
13	1	S.0456/A	CAP, BEARING -INLET END	10-25	ALUMINIUM	0,35
12	1	S.4413	HOUSING, BEARING - OUTLET SIDE	20-124	CAST IRON	6
11	1	S.4412	HOUSING, BEARING - INLET SIDE	20-123	CAST IRON	6
10	1	S.0411	NUT, KM11			
9	1	S.0410	WASHER, MB11			
8	2	S.4322	WASHER, SPRING		C.STEEL	
7	1	See 20-AB2A	SHAFT	20-10	C.STEEL	20-AB2A
6	Variable	S.0479	SHIM, IMPELLER	006	C.STEEL	
5	1	See 20-AB2A	KEY, IMPELLER	003	C.STEEL	
4	Variable	See 20-AB2A	IMPELLER	20-AB2A	ALUMINIUM	3,4
3	Variable	S.4303 E	SECTION, INTERMEDIATE	20-09	ALUMINIUM	13,2
2	1	S.4302 E	HEAD, OUTLET	20-02	ALUMINIUM	18
1	1	S.4301 E	HEAD, INLET	20-01	ALUMINIUM	16
ITEM	QTY.	PART NO.	DESCRIPTION	DWG	MATERIAL	WEIGHT:kg

<b>CONTINENTAL INDUSTRIE</b>  S <sup>t</sup> TRIVIER/MOIGNANS FRANCE	<b>TYPE 020</b> INLET END DRIVE		ASSEMBLY: _____
			DATE: 29/02/2012
<b>PARTS LIST</b> ATEX GAS		SCALE: _____	SIZE: A3 
QUOTATION: _____	DR: BD	CHKD: DR	DWG No. _____
ORDER No.: _____	REVISIONS _____		<b>20-AB2A-NM</b>
This drawing is our property and cannot be copied or communicated to thirds without our authorization.			